



The Controlflex® series



Standard

For all standard encoders



Impuls Plus

For encoders with maximum accuracy



Compact

The very short design



Industry

For robust industrial encoders

Controlflex®

Controlflex® is the ideal coupling for encoders.

Controlflex® is a compact, electrically-insulating, precise shaft coupling with excellent kinematic properties. Modular construction makes it possible to realize all possible bore combinations from stock.

Standard

The optimal choice for all standard encoders and tachos. The Standard series offers a balanced design of precision with very low restoring forces and it exactly meets the requirements of today's encoders.

SCHMIDT-KUPPLUNG 
GmbH



Francis and Francis Limited

The Stables Works, Station Road, Kenley, Surrey, CR8 5JA.

Phone: 020-8668-9792/3

Fax: 020-8668-9793

E-Mail: sales@powertransmissions.co.uk

[Http://www.powertransmissions.co.uk](http://www.powertransmissions.co.uk)

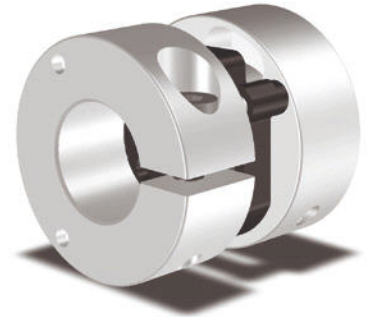
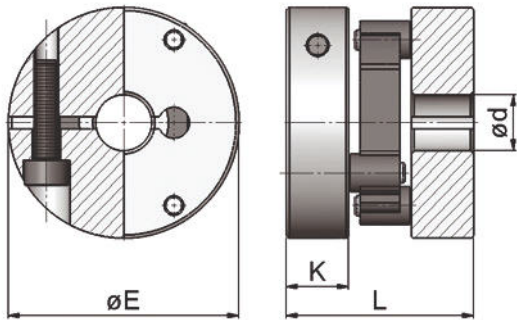

	ØE (mm)	L (mm)	Ød _{max} (mm)	Ød _{min} (mm)	K (mm)	m (kg)	J (kg cm ²)	T _{KN} (Nm)	TK _{max} (Nm)	ΔK _c (mm)	ΔK _w (°)	ΔK _a (mm)	n _{max} (1/min)	C _R (N)
CPS 8.1	19	16	10	3	5,6	0,01	0,004	0,3	0,7	0,4	1,5	0,3	25.000	3
CPS 10.1	25	25,5	12	4	9,5	0,03	0,02	0,7	1	0,7	1,5	0,5	22.000	3,4
CPS 15.1	37	30	20	5	10	0,06	0,11	2	3	1	1,5	0,7	15.000	4,4

Order Example 1: CPS 15.1 Ø10 Ø10 Order Example 2: CPS 10.1 Ø10 Ø10

CPS 15.1	Ø10 Ø10
Type Controlflex® Standard CPS 15.1	bore diameters

To ensure the correct selection of the Controlflex® please use our 'selection procedure and legend' page at the end to obtain the required information.

1. Calculation of the design torque. Please multiply your continuous torque by the required service factor to get the design torque.

service factor

uniform	1
light shocks	1,5
medium shocks	2
heavy shocks	2,5

2. Select a coupling size that has a continuous torque rating greater than your calculated design torque.
3. Make sure that the peak torque of the application does not exceed the maximum torque rating of the coupling.
4. Please check the coupling maximum speed to be sure it is under the rated maximum speed limit.
5. Make sure that the misalignment capability is sufficient. There is a trade-off between the radial, axial and angular misalignment capabilities. Be certain that the combined percentages of each do not exceed 100%.

Legend

Performance

T_{CN}	continuous torque rating of the coupling (Nm)
$T_{K\ max}$	maximum torque capacity of the coupling (Nm)
$n_{\ max}$	maximum speed of the coupling (1/min)
ΔK_r	maximum radial misalignment capacity (mm)
ΔK_a	maximum axial misalignment capacity (mm)
ΔK_w	maximum angular misalignment capacity (°)
C_R	restoring forces at 0,2 mm radial misalignment (N)
J	moment of inertia (kg cm ²)

Dimensions

ØE	coupling diameter (mm)
L	coupling length (mm)
K	clamp hub length (mm)
Ød _{max}	maximum bore diameter (mm)
Ød _{min}	minimum bore diameter (mm)
m	weight of the coupling (kg)