

### The Controlflex® series



#### Standard

For all standard encoders



#### Impuls Plus

For encoders with maximum accuracy



#### Compact

The very short design



#### Industry

For robust industrial encoders

### Controlflex®

Controlflex® is the ideal coupling for encoders.

Controlflex® is a compact, electrically-insulating, precise shaft coupling with excellent kinematic properties. Modular construction makes it possible to realize all possible bore combinations from stock.

### Impuls Plus

The Controlflex® series for encoders with maximum accuracy. It is destined for encoders using a graduated disk with increased line counts or with fine measuring signals.

► **Controflex®** ► **Impuls Plus**  
 For encoders with maximum accuracy

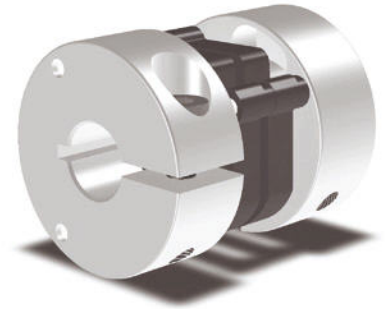
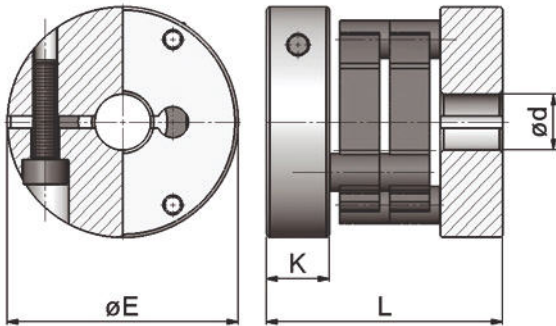

	ØE (mm)	L (mm)	Ød <sub>max</sub> (mm)	Ød <sub>min</sub> (mm)	K (mm)	m (kg)	J (kg cm <sup>2</sup> )	T <sub>KN</sub> (Nm)	T <sub>K max</sub> (Nm)	ΔK <sub>i</sub> (mm)	ΔK <sub>w</sub> (°)	ΔK <sub>a</sub> (mm)	n <sub>max</sub> (1/min)	C <sub>R</sub> (N)
CPS 8.2	19	20	10	3	5,6	0,01	0,01	0,6	1,4	0,4	1	0,3	25.000	6
CPS 10.2	25	31	12	4	9,5	0,03	0,02	1,4	2	0,7	1	0,5	22.000	6,8
CPS 15.2	37	38	20	5	10	0,07	0,12	4	6	1	1	0,7	15.000	8,8

Order Example 1: CPS 15.2 Ø10 Ø10    Order Example 2: CPS 8.2 Ø10 Ø10

CPS 8.2	Ø10 Ø10
Type Controflex® Impuls Plus CPS 8.2	bore diameters

To ensure the correct selection of the Controflex® please use our 'selection procedure and legend' page at the end to obtain the required information.

1. Calculation of the design torque. Please multiply your continuous torque by the required service factor to get the design torque.

service factor

uniform	1
light shocks	1,5
medium shocks	2
heavy shocks	2,5

2. Select a coupling size that has a continuous torque rating greater than your calculated design torque.
3. Make sure that the peak torque of the application does not exceed the maximum torque rating of the coupling.
4. Please check the coupling maximum speed to be sure it is under the rated maximum speed limit.
5. Make sure that the misalignment capability is sufficient. There is a trade-off between the radial, axial and angular misalignment capabilities. Be certain that the combined percentages of each do not exceed 100%.

## Legend

### Performance

$T_{KN}$	continuous torque rating of the coupling (Nm)
$T_{K\ max}$	maximum torque capacity of the coupling (Nm)
$n_{\ max}$	maximum speed of the coupling (1/min)
$\Delta K_r$	maximum radial misalignment capacity (mm)
$\Delta K_a$	maximum axial misalignment capacity (mm)
$\Delta K_w$	maximum angular misalignment capacity (°)
$C_R$	restoring forces at 0,2 mm radial misalignment (N)
J	moment of inertia (kg cm <sup>2</sup> )

### Dimensions

ØE	coupling diameter (mm)
L	coupling length (mm)
K	clamp hub length (mm)
Ød <sub>max</sub>	maximum bore diameter (mm)
Ød <sub>min</sub>	minimum bore diameter (mm)
m	weight of the coupling (kg)